

Stainless Steel Tubular Fittings

Ultrahigh-Purity and
Chemically Cleaned and Passivated

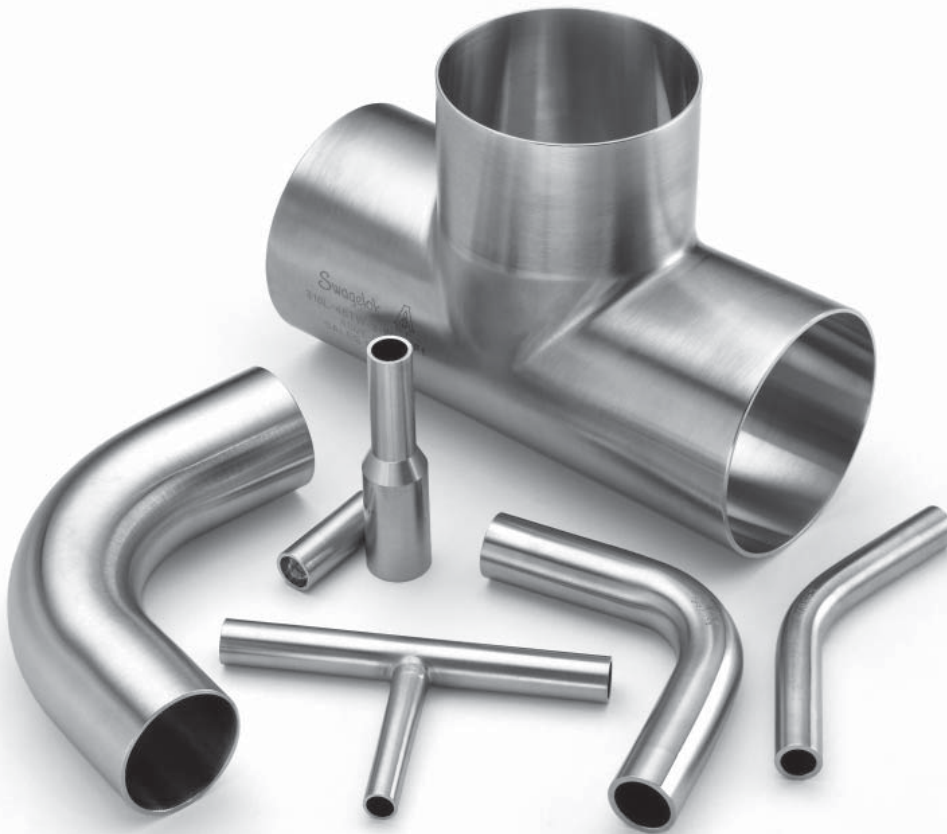

- Sizes from 1/4 through 4 in. outside diameter
- Metric sizes available upon request
- 316L stainless steel construction
- Available in a variety of configurations, including coaxial
- Marked to indicate material type and heat code

Features

Traceability

Each tubular fitting is marked to identify manufacturer, material type, and heat code.

Variety of Configurations

Tubular fittings are available in elbows, tees, reducers, end caps, and coaxial configurations.



Technical Data

Product	Inside Diameter Surface Finish	Packaging	Individual Certification	Process Designator	Material Specification	Wall Thickness	External Finish
Ultrahigh-purity	10 $\mu\text{in. } R_a$ max; electropolished	Ends are faced and protected with polyamide nylon film and polyethylene caps; packed in double polyethylene bags	Mill Test Reports Certificate of Conformance ^①	E2	ASTM A269 ASTM A479 ASTM A632	0.035 in. (1/4 and 3/8 in. OD) 0.049 in. (1/2 in. OD) 0.065 in. (3/4 to 3 in. OD) 0.083 in. (4 in. OD)	Satin
	10 $\mu\text{in. } R_a$ max, except for cold formed and welded areas; electropolished		Mill Test Reports Surface Roughness Dimensional Tolerances Helium Leak Test for welded fittings	E3			
Chemically cleaned and passivated	20 $\mu\text{in. } R_a$ max	Ends are faced and protected with polyamide nylon film and polyethylene caps; packed in a single polyethylene bag	—	G20			
	32 $\mu\text{in. } R_a$ max			G30			

Process specifications apply to process tube in coaxial tubular fittings. Process specifications are available upon request. Contact your authorized Swagelok® sales and service representative.

① Certificate of Conformance for: Surface roughness
Dimensional tolerances
Helium leak test for welded fittings
Purity test for moisture and particulates

SEM pits, inclusions, or other raw material defects
XPS minimum chromium to iron and chromium oxide to iron oxide ratios
DI water cleaning for effluent resistivity

Raw Materials

Swagelok UHP and chemically cleaned tubular fittings are manufactured from 316L stainless steel; controlled sulfur levels of 0.005 to 0.012 % (seamless) and 0.005 to 0.017 % (welded) promote reliable, consistent orbital welding.

Traceability

UHP and chemically cleaned tubular fittings are fully traceable to the original material supplier. Certificates of compliance are available upon request. Certified material test reports (CMTR) are kept on file.

Markings

UHP and chemically cleaned tubular fittings are marked with material type and heat code or trace identification, using a mechanical etching tool. Fittings having circumferential welds are helium leak-tested and marked with a lot number.

Ultrahigh-Purity

Ultrahigh-purity tubular fittings are rinsed with 18 M Ω -cm DI water and purged with filtered nitrogen. Ends are sealed in an ISO Class 4/Federal Class 10 cleanroom.

Chemically Cleaned and Passivated

Chemically cleaned and passivated tubular fittings are manufactured from 316L stainless steel. Nonvolatile residue levels are compliant with ASTM G93, Level A requirements. These fittings also meet requirements of CGA G4.1.

Ordering Information and Dimensions

Dimensions are for reference only and are subject to change.

To order, add a process designator from the **Technical Data** table, page 2, to the basic ordering number.

Example: 6L-4TW-5-S-035-E2

45° Elbow

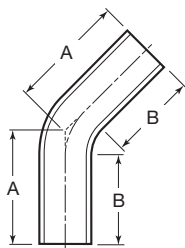

Tube OD in.	Basic Ordering Number	Dimensions, in. (mm)	
		A	B
Seamless			
1/4	6L-4TW-5-S-035-	1.10 (27.9)	0.86 (21.8)
3/8	6L-6TW-5-S-035-	2.00 (50.8)	1.76 (44.7)
1/2	6L-8TW-5-S-049-	2.50 (63.5)	2.18 (55.4)
3/4	6L-12TW-5-S-065-	2.50 (63.5)	2.03 (51.6)
1	6L-16TW-5-S-065-	3.12 (79.3)	2.49 (63.3)
1 1/2	6L-24TW-5-S-065-	2.50 (63.5)	1.50 (38.1)
2	6L-32TW-5-S-065-	3.00 (76.2)	1.75 (44.5)
Welded			
1 1/2	6L-24TW-5-W-065-	2.50 (63.5)	1.50 (38.1)
2	6L-32TW-5-W-065-	3.00 (76.2)	1.75 (44.5)
3	6L-48TW-5-W-065-	3.63 (92.2)	1.75 (44.5)
4	6L-64TW-5-W-083-	4.50 (114)	2.00 (50.8)

90° Elbow

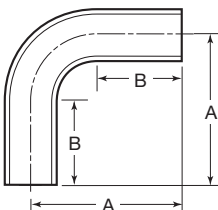

Tube OD in.	Basic Ordering Number	Dimensions, in. (mm)	
		A	B
Seamless			
1/4	6L-4TW-9-S-035-	2.06 (52.3)	1.50 (38.1)
3/8	6L-6TW-9-S-035-	2.62 (66.5)	2.06 (52.3)
1/2	6L-8TW-9-S-049-	2.62 (66.5)	1.87 (47.5)
3/4	6L-12TW-9-S-065-	2.62 (66.5)	1.50 (38.1)
1	6L-16TW-9-S-065-	4.00 (102)	2.50 (63.5)
1 1/2	6L-24TW-9-S-065-	3.75 (95.3)	1.50 (38.1)
2	6L-32TW-9-S-065-	4.75 (121)	1.75 (44.5)
Welded			
1 1/2	6L-24TW-9-W-065-	3.75 (95.3)	1.50 (38.1)
2	6L-32TW-9-W-065-	4.75 (121)	1.75 (44.5)
3	6L-48TW-9-W-065-	6.25 (159)	1.75 (44.5)
4	6L-64TW-9-W-083-	8.00 (203)	2.00 (50.8)

Concentric Reducer

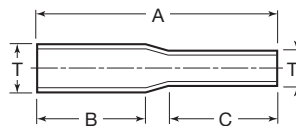

T Tube OD in.	Tx Tube OD in.	Basic Ordering Number	Dimensions in. (mm)		
			A	B	C
Seamless					
3/8	1/4	6L-6TW-6-4S-035-	2.75 (69.9)	1.37 (34.8)	1.16 (29.5)
1/2	1/4	6L-8TW-6-4S-049-035-	2.75 (69.9)	1.37 (34.8)	0.94 (23.9)
	3/8	6L-8TW-6-6S-049-035-			1.16 (29.5)
3/4	1/4	6L-12TW-6-4S-065-035-	2.75 (69.9)	1.37 (34.8)	1.09 (27.7)
	3/8	6L-12TW-6-6S-065-035-			1.16 (29.5)
	1/2	6L-12TW-6-8S-065-049-			1.23 (31.2)
1	1/4	6L-16TW-6-4S-065-035-	3.00 (76.2)	1.50 (38.1)	1.07 (27.2)
	3/8	6L-16TW-6-6S-065-035-			1.14 (29.0)
	1/2	6L-16TW-6-8S-065-049-			1.21 (30.7)
	3/4	6L-16TW-6-12S-065-			1.35 (34.3)
1 1/2	1/4	6L-24TW-6-4S-065-035-	5.50 (140)	1.50 (38.1)	1.50 (38.1)
	3/8	6L-24TW-6-6S-065-035-			
	1/2	6L-24TW-6-8S-065-049-			
	3/4	6L-24TW-6-12S-065-			
	1	6L-24TW-6-16S-065-			
2	1/4	6L-32TW-6-4S-065-035-	7.75 (197)	1.75 (44.5)	1.50 (38.1)
	3/8	6L-32TW-6-6S-065-035-			
	1/2	6L-32TW-6-8S-065-049-			
	3/4	6L-32TW-6-12S-065-			
	1	6L-32TW-6-16S-065-			
	1 1/2	6L-32TW-6-24S-065-			
Welded					
3	1	6L-48TW-6-16W-065-	11.25 (286)	1.75 (44.5)	1.50 (38.1)
	1 1/2	6L-48TW-6-24W-065-	9.25 (235)		
	2	6L-48TW-6-32W-065-	7.50 (191)		
4	1	6L-64TW-6-16W-083-065-	15.50 (394)	2.00 (50.8)	1.50 (38.1)
	1 1/2	6L-64TW-6-24W-083-065-	13.50 (343)		
	2	6L-64TW-6-32W-083-065-	11.75 (298)		
	3	6L-64TW-6-48W-083-065-	7.75 (197)		

Ordering Information and Dimensions

Dimensions are for reference only and are subject to change.

To order, add a process designator from the **Technical Data** table, page 2, to the basic ordering number.

Example: 6L-4TW-5-S-035-**E2**

Reducing Tee

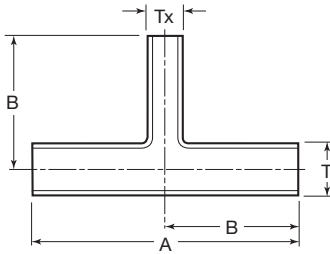

Tee

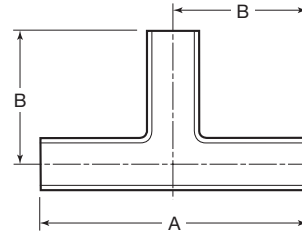

T Tube OD in.	Tx Tube OD in.	Basic Ordering Number	Dimensions in. (mm)	
			A	B
Seamless				
3/8	1/4	6L-6TW-3-4S-035-	3.50 (88.9)	1.75 (44.5)
1/2	1/4	6L-8TW-3-4S-049-035-	4.25 (108)	2.12 (53.8)
	3/8	6L-8TW-3-6S-049-035-		
3/4	1/4	6L-12TW-3-4S-065-035-	4.25 (108)	2.12 (53.8)
	3/8	6L-12TW-3-6S-065-035-		
	1/2	6L-12TW-3-8S-065-049-		
1	1/4	6L-16TW-3-4S-065-035-	5.00 (127)	2.50 (63.5)
	3/8	6L-16TW-3-6S-065-035-		
	1/2	6L-16TW-3-8S-065-049-		
	3/4	6L-16TW-3-12S-065-		
1 1/2	1/4	6L-24TW-3-4S-065-035-	4.75 (121)	2.38 (60.5)
	3/8	6L-24TW-3-6S-065-035-		
	1/2	6L-24TW-3-8S-065-049-		
	3/4	6L-24TW-3-12S-065-		
2	1	6L-24TW-3-16S-065-	5.75 (146)	2.88 (73.2)
	1/4	6L-32TW-3-4S-065-035-		
	3/8	6L-32TW-3-6S-065-035-		
	1/2	6L-32TW-3-8S-065-049-		
	3/4	6L-32TW-3-12S-065-		
	1	6L-32TW-3-16S-065-		
Welded				
1 1/2	1/4	6L-24TW-3-4W-065-035	4.75 (121)	2.38 (60.5)
	3/8	6L-24TW-3-6W-065-035		
	1/2	6L-24TW-3-8W-065-049		
	3/4	6L-24TW-3-12W-065-		
	1	6L-24TW-3-16W-065-		
2	1/4	6L-32TW-3-4W-065-035	5.75 (146)	2.88 (73.2)
	3/8	6L-32TW-3-6W-065-035		
	1/2	6L-32TW-3-8W-065-049		
	3/4	6L-32TW-3-12W-065-		
	1	6L-32TW-3-16W-065-		
	1 1/2	6L-32TW-3-24W-065-		
3	1	6L-48TW-3-16W-065-	6.75 (171)	3.12 (79.2)
	1 1/2	6L-48TW-3-24W-065-		
	2	6L-48TW-3-32W-065-		
4	1	6L-64TW-3-16W-083-065-	8.25 (210)	3.62 (91.9)
	1 1/2	6L-64TW-3-24W-083-065-		
	2	6L-64TW-3-32W-083-065-		
	3	6L-64TW-3-48W-083-065-		

Tube OD in.	Basic Ordering Number	Dimensions, in. (mm)	
		A	B
Seamless			
1/4	6L-4TW-3-S-035-	3.50 (88.9)	1.75 (44.5)
3/8	6L-6TW-3-S-035-	3.50 (88.9)	1.75 (44.5)
1/2	6L-8TW-3-S-049-	4.25 (108)	2.12 (53.8)
3/4	6L-12TW-3-S-065-	4.25 (108)	2.12 (53.8)
1	6L-16TW-3-S-065-	5.00 (127)	2.50 (63.5)
1 1/2	6L-24TW-3-S-065-	4.75 (121)	2.37 (60.2)
2	6L-32TW-3-S-065-	5.75 (146)	2.87 (72.9)
Welded			
1 1/2	6L-24TW-3-W-065-	4.75 (121)	2.37 (60.2)
2	6L-32TW-3-W-065-	5.75 (146)	2.87 (72.9)
3	6L-48TW-3-W-065-	6.75 (171)	3.37 (85.6)
4	6L-64TW-3-W-083-	8.25 (210)	4.12 (105)

End Cap

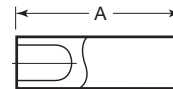

Tube OD in.	Basic Ordering Number	A in. (mm)
Seamless		
1/4	6L-4TW-C-S-035-	1.12 (28.4)
3/8	6L-6TW-C-S-035-	1.12 (28.4)
1/2	6L-8TW-C-S-049-	1.37 (34.8)
3/4	6L-12TW-C-S-065-	1.75 (44.5)
1	6L-16TW-C-S-065-	1.75 (44.5)
1 1/2	6L-24TW-C-S-065-	2.00 (50.8)
2	6L-32TW-C-S-065-	2.00 (50.8)
Welded		
3	6L-48TW-C-W-065-	2.00 (50.8)
4	6L-64TW-C-W-083-	2.50 (63.5)

Ordering Information and Dimensions

Dimensions are for reference only and are subject to change.

To order, add a process designator from the **Technical Data** table, page 2, to the basic ordering number.

Example: 6L-4TW-5-S-035-E2

Coaxial 45° Elbow

Process Tube OD in.	Containment Tube OD in.	Basic Ordering Number	Dimensions, in. (mm)	
			A	B
Seamless				
1/4	1/2	6L-CX4TW-5-S-035-	3.00 (76.2)	4.00 (102)
3/8	5/8	6L-CX6TW-5-S-035-	2.87 (72.9)	3.87 (98.3)
1/2	3/4	6L-CX8TW-5-S-049-	2.87 (72.9)	3.87 (98.3)
3/4	1	6L-CX12TW-5-S-065-	4.37 (111)	6.12 (155)
1	1 1/4	6L-CX16TW-5-S-065-	4.50 (114)	6.25 (159)

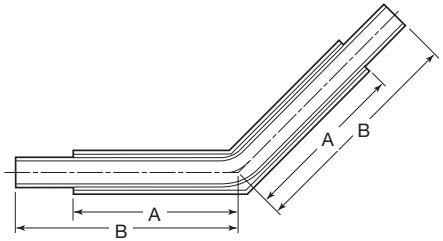

Coaxial 90° Elbow

Process Tube OD in.	Containment Tube OD in.	Basic Ordering Number	Dimensions, in. (mm)	
			A	B
Seamless				
1/4	1/2	6L-CX4TW-9-S-035-	3.37 (85.6)	4.37 (111)
3/8	5/8	6L-CX6TW-9-S-035-	3.12 (79.2)	4.12 (105)
1/2	3/4	6L-CX8TW-9-S-049-	3.25 (82.6)	4.25 (108)
3/4	1	6L-CX12TW-9-S-065-	5.00 (127)	6.75 (171)
1	1 1/4	6L-CX16TW-9-S-065-	5.37 (136)	7.12 (181)

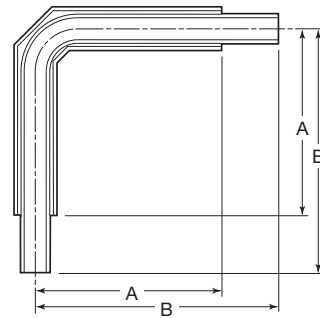

Coaxial Tee

Process Tube OD in.	Containment Tube OD in.	Basic Ordering Number	Dimensions, in. (mm)	
			A	B
Seamless				
1/4	1/2	6L-CX4TW-3-S-035-	2.87 (72.9)	3.87 (98.3)
3/8	5/8	6L-CX6TW-3-S-035-	3.00 (76.2)	4.00 (102)
1/2	3/4	6L-CX8TW-3-S-049-	3.00 (76.2)	4.00 (102)
3/4	1	6L-CX12TW-3-S-065-	4.62 (117)	6.37 (162)
1	1 1/4	6L-CX16TW-3-S-065-	4.75 (121)	6.50 (165)

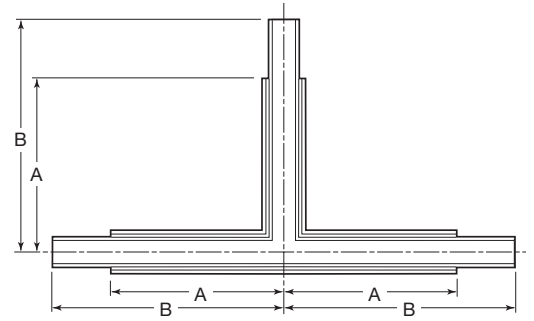

Coaxial Termination

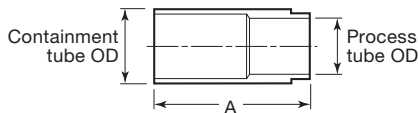

Process Tube OD in.	Containment Tube OD in.	Ordering Number	A in. (mm)
Seamless			
1/4	1/2	6L-CX4TW-TM-8S	1.25 (31.8)
3/8	5/8	6L-CX6TW-TM-10S	1.25 (31.8)
1/2	3/4	6L-CX8TW-TM-12S	1.25 (31.8)
3/4	1	6L-CX12TW-TM-16S	2.00 (50.8)
1	1 1/4	6L-CX16TW-TM-20S	2.00 (50.8)

Coaxial Sleeve Coupling

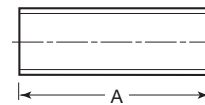

Process Tube OD in.	Ordering Number	A in. (mm)
Seamless		
1/4	6L-CX4TW-SC-8S	4.00 (102)
3/8	6L-CX6TW-SC-10S	
1/2	6L-CX8TW-SC-12S	
3/4	6L-CX12TW-SC-16S	
1	6L-CX16TW-SC-20S	

Ordering Information and Dimensions

Dimensions are for reference only and are subject to change.

To order, add a process designator from the **Technical Data** table, page 2, to the basic ordering number.

Example: 6L-4TW-5-S-035-E2

Coaxial Reducing Tee

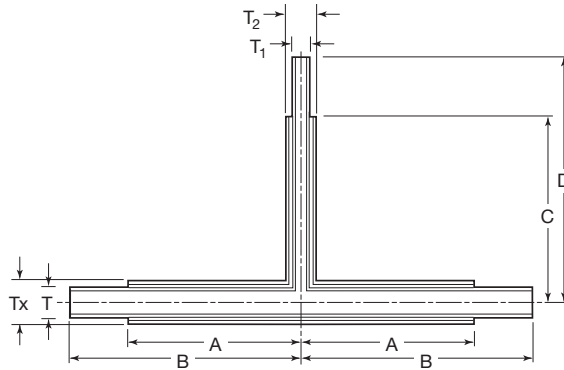

T Process Tube OD in.	Tx Containment Tube OD in.	T ₁ Process Tube OD in.	T ₂ Containment Tube OD in.	Basic Ordering Number	Dimensions in. (mm)			
					A	B	C	D
Seamless								
3/8	5/8	1/4	1/2	6L-CX6TW-3-S-4-	2.87 (72.9)	3.87 (98.3)	3.12 (79.3)	4.12 (105)
1/2	3/4	1/4	1/2	6L-CX8TW-3-S-4-	2.87 (72.9)	3.87 (98.3)	3.12 (79.3)	4.12 (105)
		3/8	5/8	6L-CX8TW-3-S-6-	3.00 (76.2)	4.00 (102)	3.12 (79.3)	4.12 (105)
3/4	1	1/4	1/2	6L-CX12TW-3-S-4-	4.37 (111)	6.12 (155)	3.25 (82.6)	4.25 (108)
		3/8	5/8	6L-CX12TW-3-S-6-	4.50 (114)	6.25 (159)	3.25 (82.6)	4.25 (108)
		1/2	3/4	6L-CX12TW-3-S-8-				
1	1 1/4	1/4	1/2	6L-CX16TW-3-S-4-	4.37 (111)	6.12 (155)	3.37 (85.6)	4.37 (111)
		3/8	5/8	6L-CX16TW-3-S-6-	4.50 (114)	6.25 (159)		
		1/2	3/4	6L-CX16TW-3-S-8-				
		3/4	1	6L-CX16TW-3-S-12-	4.62 (117)	6.37 (162)	4.87 (124)	6.62 (168)

Swagelok Tube Facing Tool and Orbital Welding System

The Swagelok tube facing tool cleanly and consistently squares tube ends in preparation for orbital welding. See the *Tube Facing Tool* catalog, MS-02-104-SCS, for more information.

The Swagelok welding system is designed to streamline welding operations and manage the total welding process. This orbital welding system includes a comprehensive package of equipment, training, accessories, and technical support to provide users with fast, repeatable, high-quality welds. See the *Swagelok Orbital Welding System Quick Reference Guide*, MS-02-143, for more information.



Safe Product Selection

When selecting a product, the total system design must be considered to ensure safe, trouble-free performance. Function, material compatibility, adequate ratings, proper installation, operation, and maintenance are the responsibilities of the system designer and user.

Warranty Information

Swagelok products are backed by The Swagelok Limited Lifetime Warranty. For a copy, visit swagelok.com or contact your authorized Swagelok representative.