

Today, a good process analyzer system just isn't good enough.

Introducing analytical instrumentation training classes from Swagelok Company.

We hear it. We see it. Whether you are at a refinery, chemical plant, or in another fluid processing business, your online process analyzer systems need to be optimized. And in today's economy you are seeking more highly trained, efficient employees. As always, Swagelok is ready to help—this time with two comprehensive training classes created for analyzer technicians, designers and engineers.

Why Swagelok Company for training?

Swagelok has served the process analyzer market for more than 60 years. We can help by refreshing knowledge for your experienced technicians and engineers, or train new staff coming online at your plant.

As a global company, our experts have solved all kinds of analytical instrumentation issues — all around the world. And we're eager to share this with you. Delivering the information are two sharp, engaging instructors: Swagelok's own Doug Nordstrom and world-renowned analyzer expert Tony Waters.

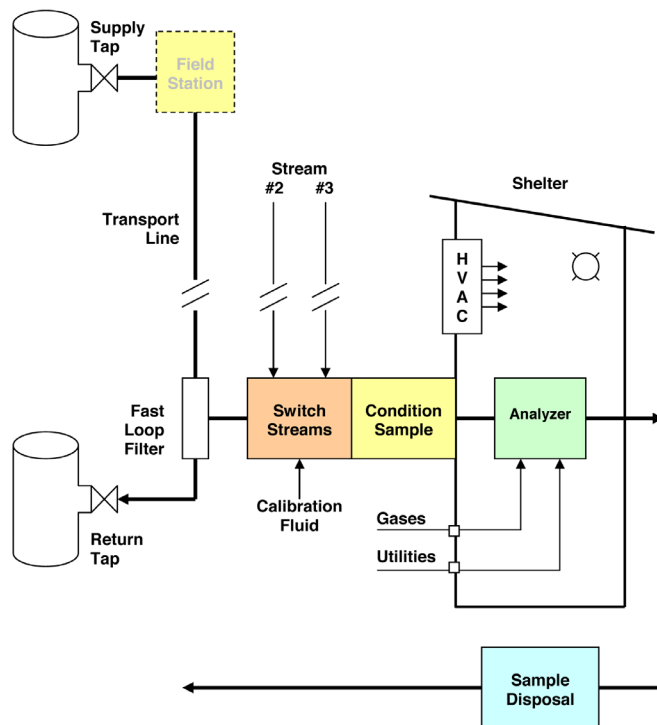

2009 Open Enrollment Dates

October 19-23
Chicago

First Quarter, 2010:
Singapore



Meet Doug Nordstrom

Analytical Instrumentation market manager, Swagelok Company.

Nordstrom focuses his efforts on advancing the company's involvement in sample-handling systems. He previously worked

in new product development for Swagelok and earned a number of Swagelok patents in products, including the Swagelok® stream selector valve (SSV) and modular platform components (MPC).

Nordstrom graduated with a bachelor of science in mechanical engineering from Case Western Reserve University and earned a master's degree in business administration from Kent State University.

"Whether you're troubleshooting or building a sampling system, these classes can deliver what you need to succeed."



Meet Tony Waters

Industry expert, respected consultant.

Waters has 45 years of experience with process analyzers and their sampling systems. He has worked in engineering and marketing roles

for an analyzer manufacturer, an end-user, and a systems integrator. He founded three companies to provide specialized analyzer services to the process industries, and is an expert in the application of process analyzers in refineries and chemical plants. Waters is particularly known for his training courses that have been presented in many of the countries of Asia, Europe, the Middle East, and North/South America. His presentations are always popular, and have equal appeal to engineers and maintenance technicians.

"There's an insatiable appetite for this kind of training — right now!"

What's the need at your company?

Are your process analyzer experts nearing retirement? Is your staff leaner, requiring the remaining associates to learn more skills? Would you like to infuse younger staffers with process analyzer skills well beyond their years?

Those who will benefit.

Process analyzer maintenance technicians
Plant analyzer engineers and chemists
Instrumentation engineers
Analyzer system design personnel
Analyzer sales engineers

Session 1:

"Troubleshooting Sampling Systems"
2-day program (Monday and Tuesday)

Oct. 19-20, Chicago
First Quarter, 2010, Singapore

Expect: A class setting, lectures, class exercises, self-evaluation tests.

Curriculum:

Basic performance criteria and difficulties

- Issues of compatibility, time delay, and representation
- Reliability, cost-effectiveness, and safe operation
- Mixing and contamination, including "dead legs"
- Adsorption and permeation
- Evaluating the process tap location

How to diagnose sample transport problems

- Simple transport time calculations for liquids and gases
- Gas compressibility and time delay

Improve sample conditioning

- The difference in composition of vapor and liquid
- Phase separation and preservation
- Troubleshooting failures

How to switch streams

- Avoid dead legs and mixing volumes
- Effective multi-stream and calibration switching methods
- Modular sample conditioning systems

Training around the world.

We bring our training classes to dynamic, hard-working cities throughout the world, offering both sessions in the same week.

Training in your offices.

As an option, we'll bring these training programs right to your office, as we've already done for other major users.

Need more info? Ready to register?

Contact your Swagelok authorized sales and service center and we'll get you more information or get you registered.

Session 2:

"Principles of Sampling System Design"
Prerequisite: "Troubleshooting Sampling Systems"
2.5-day program (Wednesday, Thursday, Friday 1/2 day)

Oct. 21-23, Chicago
First Quarter, 2010, Singapore

Expect: A hands-on experience, lectures, demonstrations, class exercises, self-evaluation tests, small groups building miniature sampling systems.

Curriculum:

Improve sampling extraction technique

- Know the process conditions, analyzer characteristics, and sample requirements
- Sample tap and probe design issues
- When a field station is desirable...or essential
- How to sample high-pressure gas lines

Design issues for fast loops and sample return lines

- Calculating the required flow rate (it's not just time delay)
- Laminar or turbulent flow (Reynolds number)
- Turbulent friction factors for typical transport lines
- The effect of temperature and pressure
- Calculating the pressure drop in each line segment

Phase conversion and preservation

- When and how to condense or vaporize a sample
- Dealing with aerosols, emulsions, and foams
- When do gases condense and by how much?

Using modular sampling components

- Review of NeSSI specifications, and current status
- How to configure modular systems